

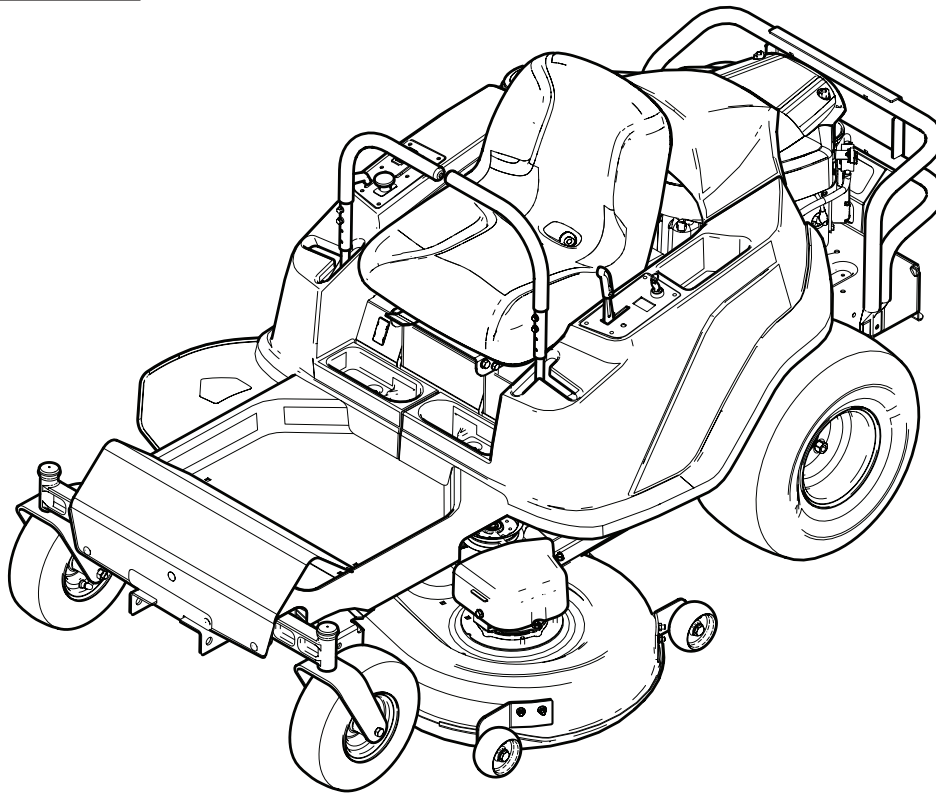

Operator's Manual



Zero Turn Rider

Mfg. No.	Description
2691136-00	Zero Turn Rider with 42" Mower

General Information

Thank you for purchasing this quality-built Snapper riding mower. We're pleased that you've placed your confidence in the Snapper brand. When operated and maintained according to the instructions in this manual, your Snapper riding mower will provide many years of dependable service.

This manual contains safety information to make you aware of the hazards and risks associated with mowers and how to avoid them. Because Briggs & Stratton Power Products Group, LLC does not necessarily know all the applications this mower could be used for, it is important that you read and understand these instructions. **Save these original instructions for future reference.**

Product Identification Tag

Product Identification Tag	
	
Model / Modèle / Model	xxxxxxx
	
Serial / Série / Serie	xxxxxxxxx
Briggs & Stratton Power Products Group, L.L.C. Milwaukee, WI 53201 USA	

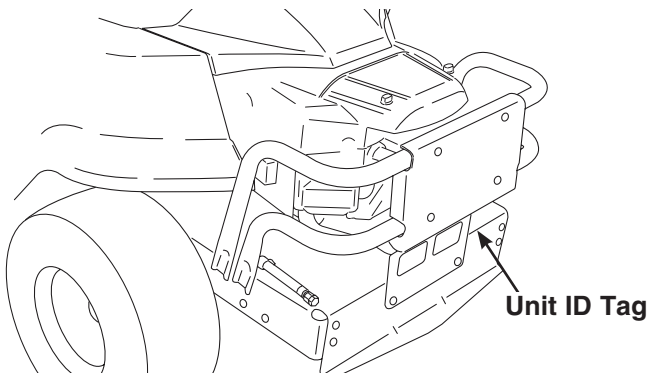

Product Reference Data

When contacting your authorized dealer for replacement parts, service, or information you MUST have these numbers.

Record your model name/number, manufacturer's identification numbers, and engine serial numbers in the space provided for easy access. These numbers can be found in the locations shown.

NOTE: For location of engine identification numbers, refer to the engine owner's manual.

PRODUCT REFERENCE DATA	
Model Description Name/Number	
Unit MFG Number	Unit SERIAL Number
Mower Deck MFG Number	Mower Deck SERIAL Number
Dealer Name	Date Purchased
ENGINE REFERENCE DATA	
Engine Make	Engine Model
Engine Type/Spec	Engine Code/Serial Number

The Illustrated Parts List for this machine can be downloaded from www.snapper.com. Please provide model and serial number when ordering replacement parts.

Copyright © 2013 Briggs & Stratton Power Products Group, LLC.
Milwaukee, WI, USA. Milwaukee, WI, USA. All rights reserved.

SNAPPER is a trademark of
Briggs & Stratton Power Products Group, LLC.

Table of Contents

Operator Safety	4	Adjustments and Service	23
Safety Interlock System Tests	12	Seat and Ground Speed Lever Adjustments	23
Features and Controls	13	Cutting Height Adjustment	24
Control Functions	13	Mower Removal and Installation	24
Operation	15	Check Mower Blade Stopping Time	25
General Operating Safety	15	Cleaning the Battery and Cables	26
Checks Before Starting	15	Battery Charging	26
Starting the Engine	16	Troubleshooting	27
Stopping the Rider and Engine	16	Troubleshooting the Rider	27
Mowing	16	Troubleshooting the Mower	28
Pushing the Rider by Hand	16	Specifications	29
Zero Turn Driving Practice	17	Warranty	30
Attaching a Trailer	19		
Maintenance	20		
Maintenance Chart	20		
Checking Tire Pressures	21		
Checking/Adding Fuel	21		
Fuel Filter	21		
Engine Maintenance	21		
Storage	22		

Operator Safety



Operating Safety

Congratulations on purchasing a superior-quality piece of lawn and garden equipment. Our products are designed and manufactured to meet or exceed all industry standards for safety.

Do not operate this machine unless you have familiarized yourself with it. Reading and understanding this operator's manual is a way to do just that.

Power equipment is only as safe as the operator. If it is misused, or not properly maintained, it can be dangerous! Remember, you are responsible for your safety and that of those around you.

Use common sense, and think through what you are doing. If you are not sure that the task you are about to perform can be safely done with the equipment you have chosen, ask a professional: contact your local authorized dealer.

Read the Manual

The operator's manual contains important safety information you need to be aware of **BEFORE** you operate your unit as well as **DURING** operation.

Safe operating techniques, an explanation of the product's features and controls, and maintenance information is included to help you get the most out of your equipment investment.

Be sure to completely read the Safety Rules and Information found on the following pages. Also completely read the Operation section.

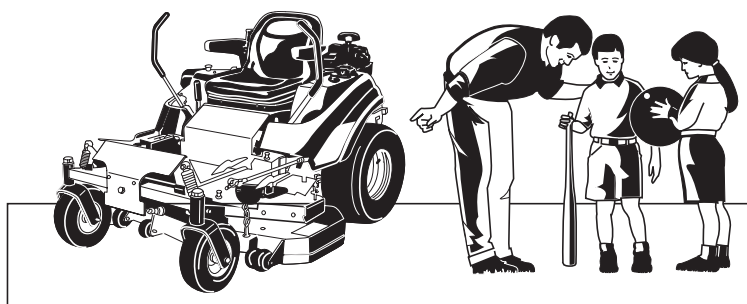
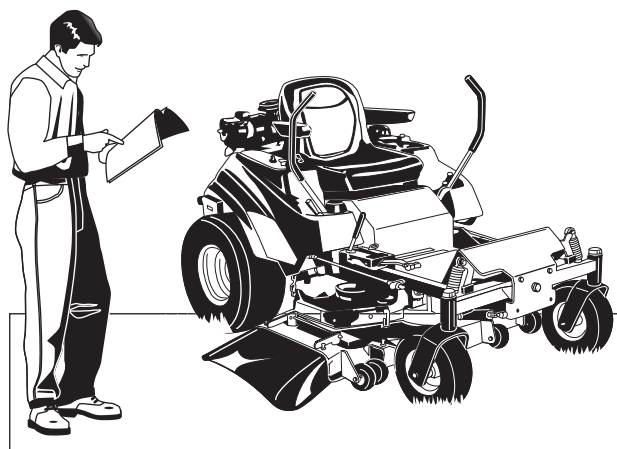

Children

Tragic accidents can occur with children. Do not allow them anywhere near the area of operation. Children are often attracted to the unit and mowing activity. Never assume that children will remain where you last saw them. If there is a risk that children may enter the area where you are mowing, have another responsible adult watch them.

Slope Operation

Operation on slopes can be dangerous. Using the unit on a slope that is too steep where you do not have adequate wheel traction (and control) can cause sliding, loss of steering, control, and possible rollover. You should not operate on a slope greater than a 3.5 foot rise over a 20 foot length (10 degrees).

Always mow up and down slopes, not across, and avoid sudden turns or rapid speed changes. Reduce speed and use extreme caution on ALL slopes.

Also, note that the surface condition you are on can greatly impact your ability to safely operate this machine. Operating on wet or slippery slopes can cause sliding and loss of steering and control. Do not operate on slopes that are slippery, wet, or have soft soil conditions.

If you feel unsure about operating the unit on a slope, don't do it. It's not worth the risk.

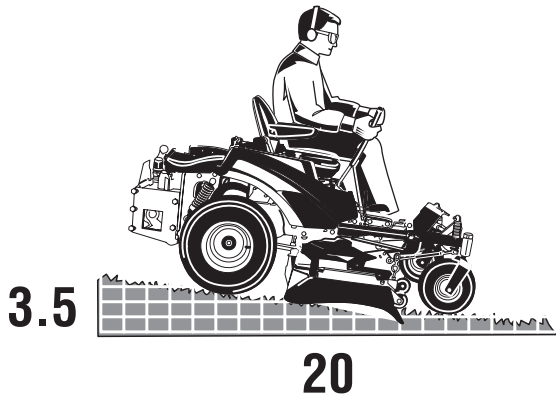

Thrown Objects

This unit has spinning mower blades. These blades can pick up and throw debris that could seriously injure a bystander. Be sure to clean up the area to be mowed and remove objects that could be thrown by the blade **BEFORE** you start mowing. Do not operate this unit without the entire grass catcher or discharge guard (deflector) in place.

Also, do not allow anyone in the area while the unit is running! If someone does enter the area, shut the unit off immediately until they leave.

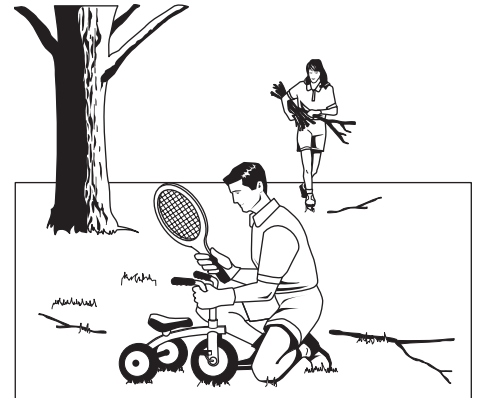

Moving Parts

This equipment has many moving parts that can injure you or someone else. However, if you stay in the operator zone (stay seated in the seat), and follow the safety rules in this operator's manual, the unit is safe to operate.

The mower deck has spinning mower blades that can amputate hands and feet. Do not allow anyone near the unit while it is running! Keep safety devices (guards, shields, and switches) in place and working.

To help you, the operator, use this equipment safely, it is equipped with an operator-present safety system. Do **NOT** attempt to alter or bypass the system. See your dealer immediately if the system does not pass all the safety interlock system tests found in this manual

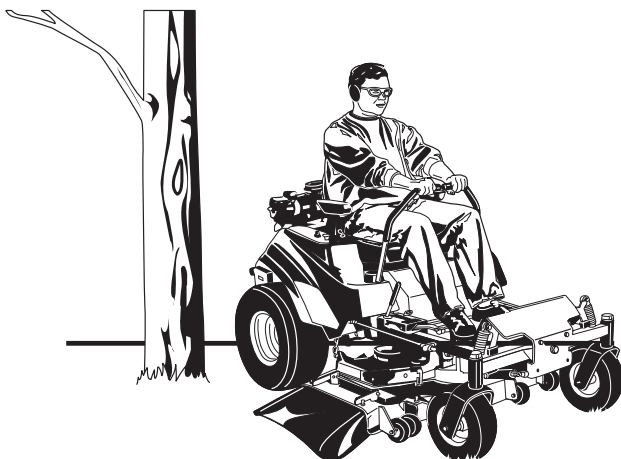

Retaining Walls, Drop-Offs, and Water

Retaining walls and drop-offs around steps and water are a common hazard. Give yourself a minimum of two mower widths of clearance around these hazards and hand-trim with a walk behind mower or string trimmer. Wheels dropping over retaining walls, edges, ditches, embankments, or into water can cause rollovers, which may result in serious injury, death, or drowning.

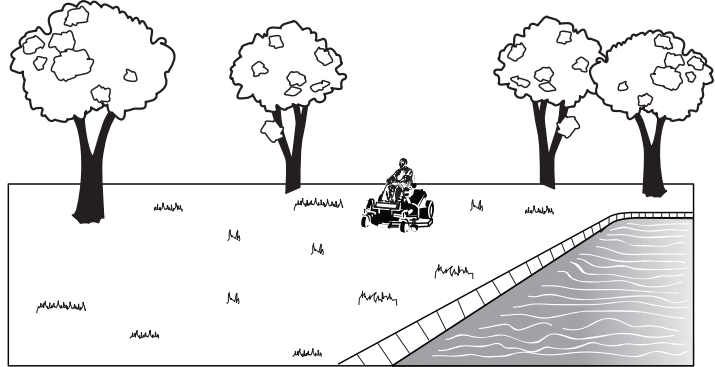
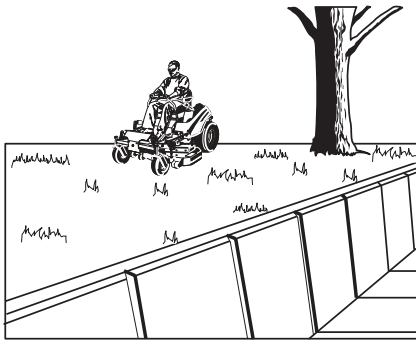

Fuel and Maintenance

Always disengage all drives, shutoff the engine, and remove the key before doing any cleaning, refueling, or servicing.

Gasoline and its vapors are extremely flammable. Do not smoke while operating or refueling. Do not add fuel while engine is hot or running. Allow engine to cool for at least 3 minutes prior to adding fuel.

Do not add fuel indoors, in an enclosed trailer, garage, or any other enclosed area that is not well ventilated. Gasoline spills should be cleaned up promptly and before operation begins.

Gasoline should be stored only in sealed containers approved for fuel.

Proper maintenance is critical to the safety and performance of your unit. Keep the unit free of grass, leaves, and excess oil. Be sure to perform the maintenance procedures listed in this manual, especially periodically testing the safety system.

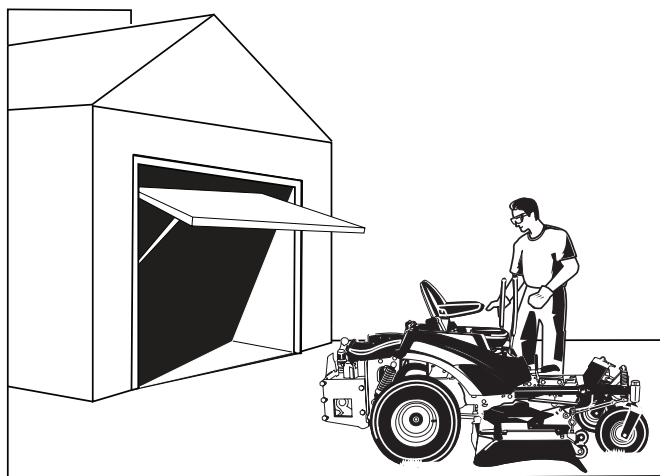
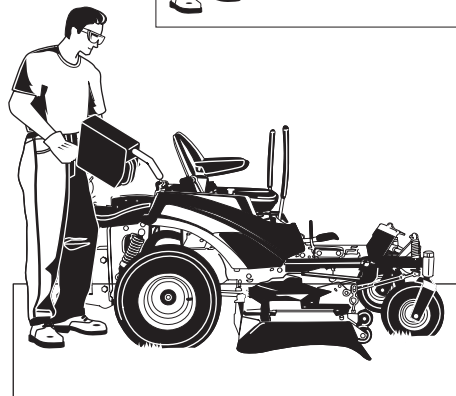
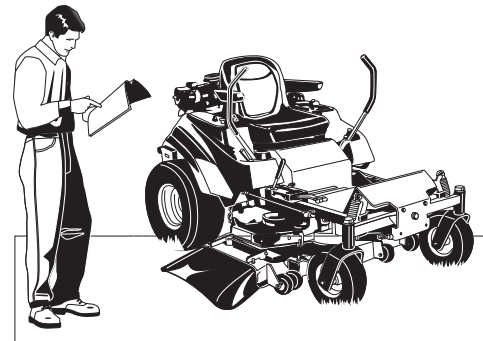

Enclosed Areas

Only operate this unit outdoors and away from unventilated areas such as inside garages or enclosed trailers. The engine emits poisonous carbon monoxide gas and prolonged exposure in an enclosed area can result in serious injury or death.

WARNING: This powerful cutting machine is capable of amputating hands and feet and can throw objects that can cause injury and damage! Failure to comply with the following SAFETY instructions could result in serious injury or death to the operator or other persons. The owner of the machine must understand these instructions and must allow only persons who understand these instructions to operate machine. Each person operating the machine must be of sound mind and body and must not be under the influence of any substance, which might impair vision, dexterity or judgment. If you have any questions pertaining to your machine which your dealer cannot answer to your satisfaction, contact the Customer Service Department.

Protection for Children

Tragic accidents can occur if the operator is not alert to the presence of children. Children are often attracted to the machine and the mowing activity. Children who have been given rides in the past may suddenly appear in the mowing area for another ride and be run over or backed over by the machine. Never assume that children will remain where you last saw them.

1. KEEP children out of the mowing area and under the watchful care of a responsible adult other than the operator.
2. DO NOT allow children in yard when machine is operated (even with the blade OFF).
3. DO NOT allow children or others to ride on machine, attachments or towed equipment (even with the blades OFF). They may fall and be seriously injured.
4. DO NOT allow pre-teenage children to operate machine.
5. ALLOW only responsible adults & teenagers with mature judgment under close adult supervision to operate machine.
6. DO NOT operate blades in reverse. STOP BLADES. LOOK and SEE behind and down for children, pets and hazards before and while backing.
7. USE EXTRA CARE when approaching blind corners, shrubs, trees, or other objects that may obscure vision.

Protection Against Tipovers

Slopes are a major factor related to loss-of-control and tip-over accidents, which can result in severe injury or death. All slopes require extra CAUTION. If you cannot back up the slope or if you feel uneasy on the slope, DO NOT mow it. Use extra care with grass catchers or other attachments; these affect the handling and the stability of the machine.

1. DO NOT operate machine on slopes exceeding 10 degrees (18% grade).
2. Exercise EXTREME CAUTION on all slopes. Turn blades OFF when traveling uphill. Use a slow speed and avoid sudden or sharp turns.
3. DO NOT operate machine back and forth across face of slopes. Operate up and down. Practice on slopes with blades off.
4. AVOID starting, stopping or turning on slopes. If machine stops going uphill or tires lose traction, turn blades OFF and back slowly straight down the slope.
5. STAY ALERT for holes and other hidden hazards. Tall grass can hide obstacles. Keep away from ditches, washouts, culverts, fences and protruding objects.

Protection Against Tipovers

(Continued From Previous Column)

6. KEEP A SAFE DISTANCE (at least 3 feet) away from edge of ditches and other drop offs. The machine could turn over if an edge caves in.
7. Always begin forward motion slowly and with caution.
8. Use weights or a weighted load carrier in accordance with instructions supplied with a grass catcher. DO NOT operate machine on slopes exceeding 10 degrees (18% grade) when equipped with grass catcher.
9. DO NOT put your foot on the ground to try to stabilize the machine.
10. DO NOT operate machine on wet grass. Reduced traction could cause sliding.
11. Chose a low enough speed setting so that you will not have to stop or shift on a slope. Tires may lose traction on slopes even though the brakes are functioning properly.
12. DO NOT operate machine under any condition where traction, steering or stability is doubtful.
13. Always keep the machine in gear when going down slopes. DO NOT shift to neutral (or actuate hydro roll release) and coast downhill.

Preparation

1. Read, understand, and follow instructions and warnings in this manual and on the machine, engine and attachments. Know the controls and the proper use of the machine before starting.
2. Only mature, responsible persons shall operate the machine and only after proper instruction.
3. Data indicates that operators age 60 and above, are involved in a large percentage of mower-related injuries. These operators should evaluate their ability to operate the mower safely enough to protect themselves and others from serious injury.
4. Handle fuel with extra care. Fuels are flammable and vapors are explosive. Use only an approved fuel container. DO NOT remove fuel cap or add fuel with engine running. Add fuel outdoors only with engine stopped and cool. Clean spilled fuel from machine. DO NOT smoke.
5. Practice operation of machine with BLADES OFF to learn controls and develop skills.

Preparation

(Continued From Previous Page)

6. Check the area to be mowed and remove all objects such as toys, wire, rocks, limbs and other objects that could cause injury if thrown by blade or interfere with mowing.
7. Keep people and pets out of mowing area. Immediately STOP blades, STOP engine, and STOP machine if anyone enters the area.
8. Check shields, deflectors, switches, blade controls and other safety devices frequently for proper operation and location.
9. Make sure all safety decals are clearly legible. Replace if damaged.
10. Protect yourself when mowing and wear safety glasses, long pants and substantial footwear.
11. Know how to STOP blades and engine quickly in preparation for emergencies.
12. Use extra care when loading or unloading the machine into a trailer or truck.
13. Check grass catcher components frequently for signs of wear or deterioration and replace as needed to prevent injury from thrown objects going through weak or worn spots.

Safe Handling of Gasoline

To avoid personal injury or property damage, use extreme care in handling gasoline. Gasoline is extremely flammable and the vapors are explosive.

1. Extinguish all cigarettes, cigars, pipes and other sources of ignition.
2. Use only an approved fuel container.
3. DO NOT remove fuel cap or add fuel with the engine running. Allow the engine to cool before refueling.
4. DO NOT refuel the machine indoors.
5. DO NOT store the machine or fuel container inside where there is an open flame, spark or pilot light such as on a water heater or other appliances.
6. DO NOT fill fuel containers inside a vehicle or on a truck or trailer bed with a plastic liner. Always place the containers on the ground away from the vehicle before filling.
7. Remove gas-powered equipment from the vehicle or trailer and refuel it on the ground. If this is not possible, then refuel equipment using a portable container, rather than a gasoline dispenser nozzle.
8. DO NOT start gas powered equipment in enclosed vehicles or trailers.
9. Keep the nozzle in contact with the rim of the fuel tank or container opening at all times until fueling is complete. DO NOT use a nozzle lock-open device.
10. If fuel is spilled on clothing, change clothing immediately.
11. Never overfill a fuel tank. Replace fuel cap and tighten securely.

OPERATION

1. Mount and dismount machine from left side. Keep clear of discharge opening at all times.
2. Start engine from operator's seat, if possible. Make sure blades are OFF and parking brake is set.

3. DO NOT leave machine with engine running. STOP engine, STOP blades, SET brake, and Remove key before leaving operators position of any reason.
4. DO NOT operate machine unless properly seated with feet on feet rests or pedal(s).
5. STOP BLADES and ENGINE and make sure blades have stopped before removing grass catcher or unclogging mower to prevent loss of fingers or hand.
6. Blades must be OFF except when cutting grass. Set blades in highest position when mowing over rough ground.
7. Keep hands and feet away from rotating blades underneath deck. DO NOT place foot on ground while BLADES are ON or machine is in motion.
8. DO NOT operate machine without entire grass catcher or guards in place and working. DO NOT point discharge at people, passing cars, windows or doors.
9. Slow down before turning.
10. Watch out for traffic when near or crossing roadways.
11. STOP engine immediately after striking an obstruction. Inspect machine and repair damage before resuming operation.
12. Operate machine only in daylight or with good artificial light.
13. Move joystick (if equipped) SLOWLY to maintain control during speed and directional changes.
14. Exercise CAUTION when pulling loads. Limit loads to those you can safely control and attach loads to hitch plate as specified with attachment instructions.
15. On slopes, the weight of the towed equipment may cause loss of traction and loss of control. When towing, travel slowly and allow extra distance to stop.
16. DO NOT operate engine in enclosed areas. Engine exhaust gases contain carbon monoxide, a deadly poison.
17. DO NOT discharge material against a wall or obstruction. Material may ricochet back towards the operator.
18. Only use accessories approved by the manufacturer. See manufacturer's instructions for proper operation and installation of accessories.

Emissions

1. Engine exhaust from this product contains chemicals known, in certain quantities, to cause cancer, birth defects, or other reproductive harm.
2. Look for the relevant Emissions Durability Period and Air Index information on the engine emissions label.

Towing

1. Tow only with a machine that has a hitch designed for towing. DO NOT attach towed equipment except at the hitch point.
2. Follow the manufacturer's recommendation for weight limits for towed equipment and towing on slopes.
3. DO NOT allow children or others on towed equipment.
4. On slopes, the weight of the towed equipment may cause loss of traction and loss of control.
5. Travel slowly and allow extra distance to stop.

Maintenance

1. DO NOT store machine or fuel container inside where fumes may reach an open flame, spark or pilot light such as in a water heater, furnace, clothes dryer or other gas appliance. Allow engine to cool before storing machine in an enclosure. Store fuel container out of the reach of children in a well ventilated, unoccupied building.
2. Keep engine free of grass, leaves or excess grease to reduce fire hazard and engine overheating.
3. When draining fuel tank, drain fuel into an approved container outdoors and away from open flame.
4. Check brakes frequently; adjust, repair or replace as needed.
5. Keep all bolts, nuts and screws properly tight. Check that all cotter pins are in proper position.

Maintenance

(Continued From Previous Column)

6. Always provide adequate ventilation when running engine. Exhaust gases contain carbon monoxide, an odorless and deadly poison.
7. Disconnect negative (black) cable from battery before performing maintenance or service. Cranking engine could cause injury.
8. DO NOT work under machine without safety blocks.
9. Service engine and make adjustments only when engine is stopped. Remove spark plug wire(s) from spark plug(s) and secure wire(s) away from spark plug(s).
10. DO NOT change engine governor speed settings or overspeed engine.
11. Lubricate machine at intervals specified in manual to prevent controls from binding.
12. Mower blades are sharp and can cut. Wrap the blades or wear heavy leather gloves and use CAUTION when handling them.
13. DO NOT test for spark by grounding spark plug next to spark plug hole; spark plug could ignite gas exiting engine.
14. Have machine serviced by an authorized dealer at least once a year and have the dealer install any new safety devices.
15. Maintain or replace safety and instruction labels as necessary.
16. Use only factory authorized replacement parts or like parts when making repairs.

WARNING

Grass Catcher bags used on this product are made of woven fabric, and are subject to deterioration and wear during normal usage. Check condition of bags before each use. Immediately replace worn or damaged catcher bags with only bags recommended by the manufacturer. The Grass Catcher is optional equipment on some models.

WARNING

Engine exhaust, some of its constituents, and certain vehicle components contain or emit chemicals known to the State of California to cause cancer or other reproductive harm.

WARNING

Battery posts, terminals and related accessories contain lead and lead compounds, chemicals known to the State of California to cause cancer and birth defects or other reproductive harm. Wash hands after handling.

SUGGESTED GUIDE FOR SIGHTING SLOPES FOR SAFE OPERATION

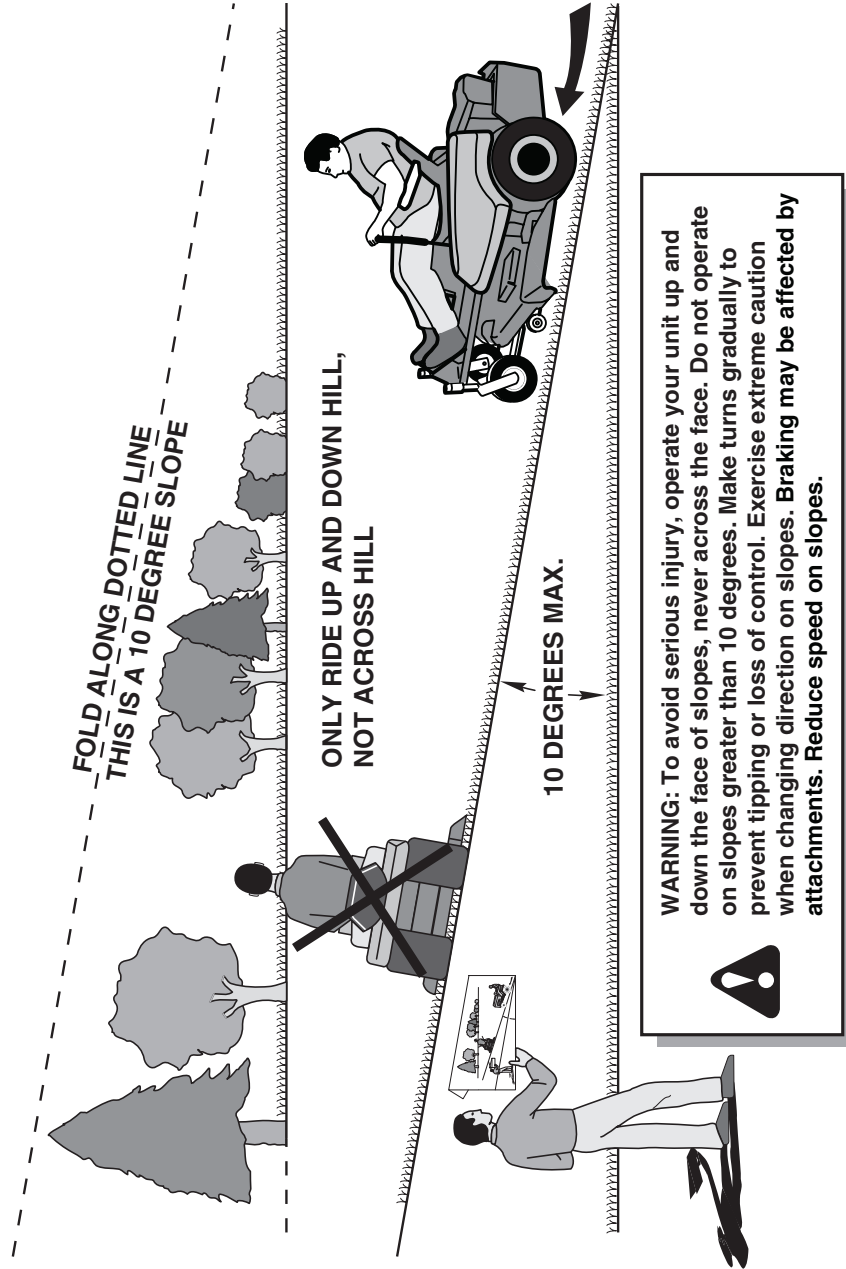

1. Fold this page along dotted line indicated above.
2. Hold page before you so that its left edge is vertically parallel to a tree trunk or other upright structure.
3. Sight across the fold in the direction of hill slope you want to measure.
4. Compare the angle of the fold with the slope of the hill.

Safety and Instructional Decals

All DANGER, WARNING, CAUTION and instructional messages on your rider and mower should be carefully read and obeyed. Personal bodily injury can result when these instructions are not followed. The information is for your safety and it is important! The safety decals below are on your rider and mower.

If any of these decals are lost or damaged, replace them at once. See your local dealer for replacements.

These decals are easily applied and will act as a constant visual reminder to you, and others who may use the equipment, to follow the safety instructions necessary for safe, effective operation.

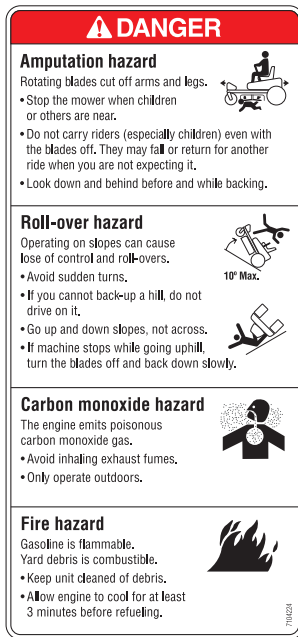

**Decal, Danger
Part No. 7104224**



**Decal, Warning
Part No. 1734273**

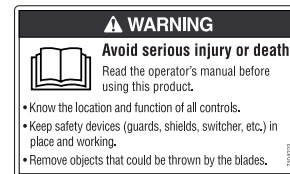

**Decal, Warning
Part No.
7104223**



**Decal, Danger
Part No. 1704276**



**Decal, Danger
Part No. 1704277**

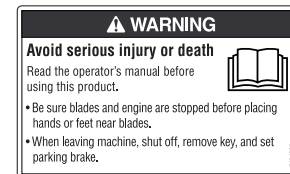

**Decal, Warning
Part No.
7104225**



**Decal, Caution
Part No. 7104393**

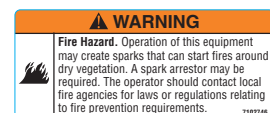

**Decal, Warning
Part No. 7102746**

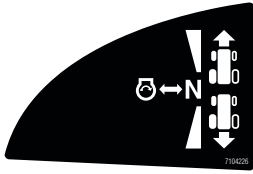

Decal, Ground Speed Lever, L.H.
Part No. 7104226

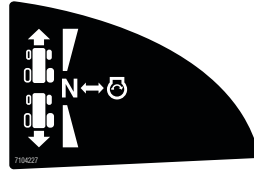

Decal, Ground Speed Lever, R.H.
Part No. 7104227

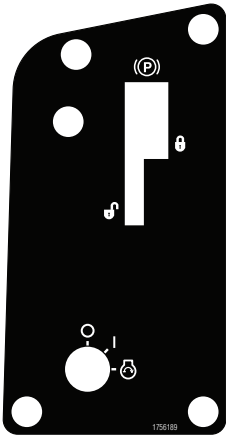

Decal, Control Panel, L.H.
Part No. 1756189

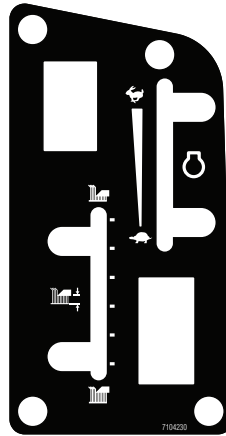

Decal, Control Panel, R.H.
Part No. 7104230

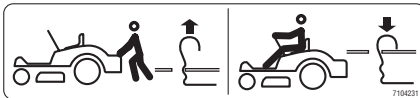

Decal, Transmission Release
Part No. 7104231

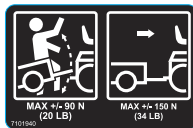

Decal, Weight Limit
Part No. 7101940

Safety Interlock System Tests

This unit is equipped with a Safety Interlock System. Do not attempt to bypass or tamper with the switches/devices.

TEST 1 — ENGINE SHOULD NOT CRANK IF:

- PTO switch is engaged, OR
- Parking brake is disengaged, OR
- Ground speed levers are not locked in their START/PARK positions.

TEST 2 — ENGINE SHOULD CRANK IF:

- PTO switch is NOT engaged, AND
- Parking brake is engaged, AND
- Ground speed levers are locked into their START/PARK positions.

TEST 3 — ENGINE SHOULD SHUT OFF IF:

- Operator rises off seat with PTO engaged, OR
- Operator rises off seat with parking brake disengaged, OR
- Operator rises off seat with ground speed levers not locked in their START/PARK positions.

TEST 4 — CHECK MOWER BLADE STOPPING TIME

The mower blades and mower drive belt should come to a complete stop within five seconds after the electric PTO switch is turned off. If mower drive belt does not stop within five seconds, see your dealer.

NOTE: Once the engine has stopped, the PTO switch must be turned off, the parking brake must be engaged, and the ground speed levers must be locked in their START/PARK positions in order to start the engine.

! WARNING

If the unit does not pass a safety test, do not operate it. See an authorized dealer.

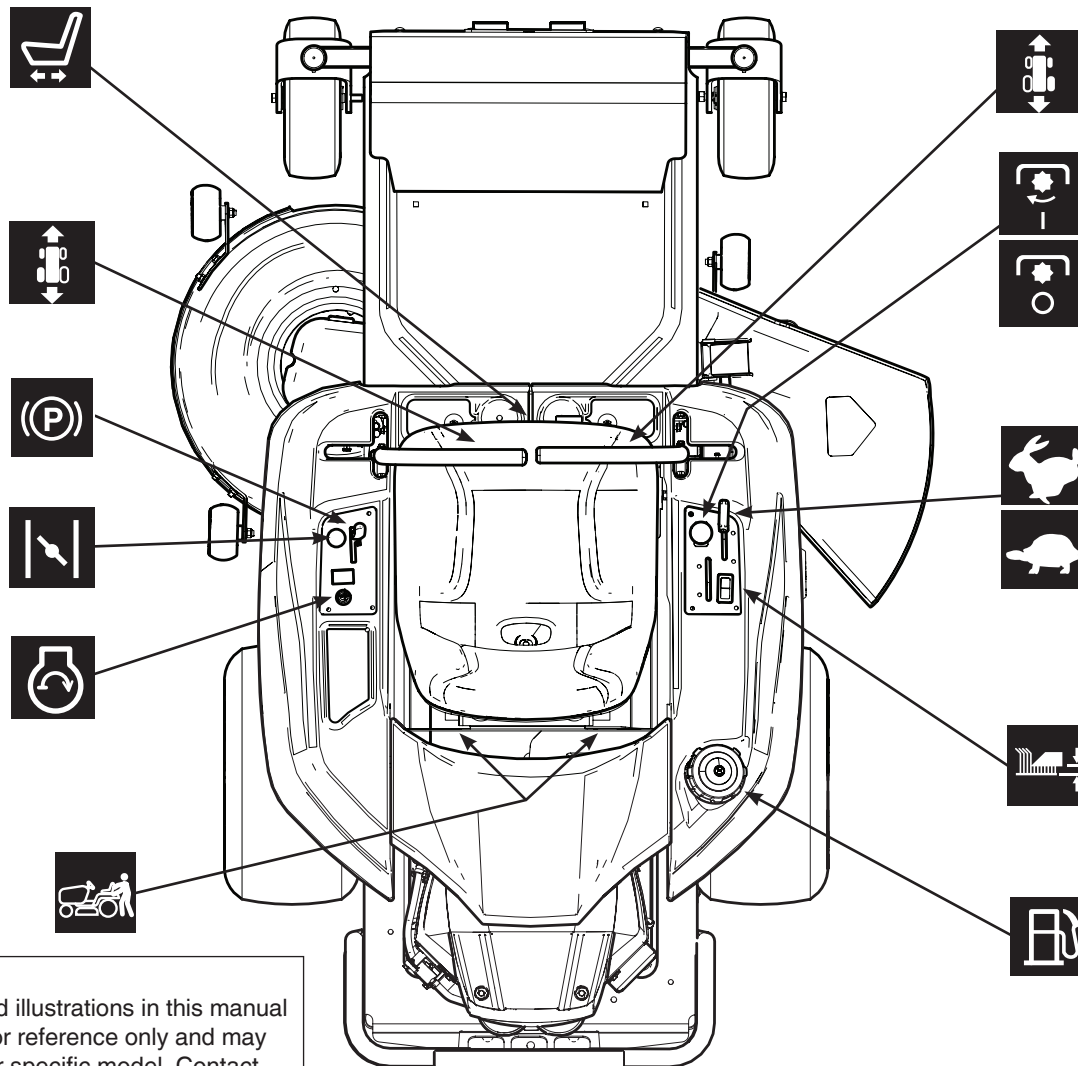

IMPORTANT

The figures and illustrations in this manual are provided for reference only and may differ from your specific model. Contact your dealer if you have questions.

Control Functions

The information below briefly describes the function of individual controls. Starting, stopping, driving, and mowing require the combined use of several controls applied in specific sequences. To learn what combination and sequence of controls to use for various tasks see the **Operation** section.



Ground Speed Levers

These levers control the ground speed and direction of the rider. The left lever controls the left rear drive wheel and the right controls the right rear drive wheel.

Moving a lever forward increases the FORWARD speed of the associated wheel, and pulling back on a lever increases the REVERSE speed.

The further a lever is moved away from the neutral position the faster the drive wheel will turn.

See the **Operation** section for steering instructions.



Choke Control

Move the choke control to the CHOKE position to start a cold engine. A warm engine may not require choking.





Engine Speed Control

Move the engine speed control to the FAST position to increase engine speed, and to the SLOW position to decrease engine speed.

NOTE: Always operate the rider with the engine speed control in the FAST position.

Ignition Switch

The ignition switch starts and stops the engine; it has three positions:

-  OFF Stops the engine and shuts off the electrical system.
-  RUN Allows the engine to run and powers the electrical system.
-  START Cranks the engine for starting.

NOTE: Never leave the ignition switch in the RUN position with the engine stopped—this drains the battery.

PTO Switch

The PTO (Power Take-Off) switch engages and disengages the mower blade clutch. To engage the PTO, pull UP on the switch. Push DOWN to disengage. Note that the operator must be seated firmly in the rider seat for the PTO to function.

Transmission Release Levers

The transmission release levers deactivate the transmissions so that the unit can be pushed by hand (see *Pushing the Unit by Hand*).

Seat Adjustment Lever

The seat can be adjusted forward and backward (see *Seat Adjustments*).

Fuel Tank Cap

To remove the cap, turn counterclockwise.

Mower Cutting Height Adjustment Switch

The mower cutting height is adjustable between 1.00” (2,54 cm) and 3.75” (9,53 cm). See *Cutting Height Adjustment*.

Parking Brake

Moving the parking brake lever forward and to the right engages the parking brake. Moving the lever to the left and back disengages the brake.

General Operating Safety

Before first time operation:

- Be sure to read all information in the **Operator Safety** section before attempting to operate this rider and mower.
- Become familiar with all of the controls and how to stop the unit.
- Drive in an open area without mowing to become accustomed to driving the unit.

⚠ WARNING

Never operate on slopes greater than 18 percent (10°).

Select slow ground speed before driving onto a slope. Use extra caution when operating on slopes with a rear-mounted grass catcher.

Mow up and down slopes, not across the face, use caution when changing directions and **DO NOT START OR STOP ON SLOPE.**

⚠ WARNING

Never allow passengers to ride on the unit.

Before leaving the operator's position for any reason, lock the ground speed levers in the **START/PARK** position, engage the parking brake, disengage the PTO, stop the engine and remove the key.

To reduce fire hazard, keep the engine, rider and mower free of grass, leaves and excess grease. Do not stop or park rider over dry leaves, grass or combustible materials.

Gasoline is highly flammable and must be handled with care. Never fill the tank when the engine is still hot from recent operation. Do not allow open flame, smoking or matches in the area. Avoid over-filling and wipe up any spills.

⚠ WARNING

If you do not understand how a specific control functions, or have not yet thoroughly read the **Features and Controls** section, do so now. **Do NOT** attempt to operate the rider without first becoming familiar with the location and function of **ALL** controls.

Checks Before Starting

- Check that the crankcase is filled to full mark on dipstick (**A**, Figure 1 - located under engine cover on some models). See the engine owner's manual for instructions and oil recommendations.
- Make sure all nuts, bolts, screws and pins are in place and secure.
- Adjust the seat position (**B**), and make certain you can reach all controls from the operator's position.
- Fill the fuel tank (**C**) with fresh fuel. Refer to the engine owner's manual for fuel recommendations.

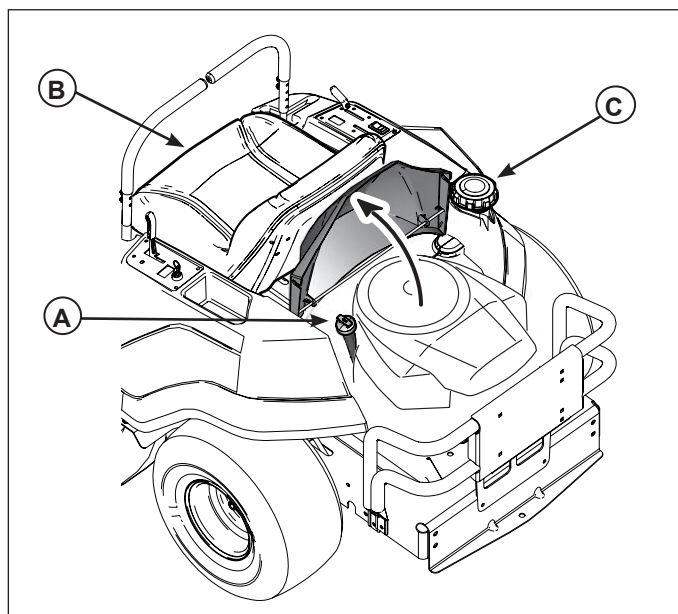
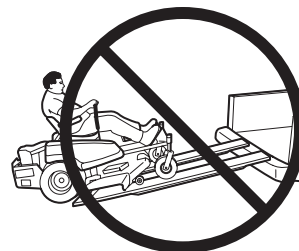

Figure 1. Pre-Start Checks

⚠ WARNING

Do not load this zero-turn rider on a trailer or truck using two separate ramps. Only use a single ramp that is at least one foot wider than the width of the rear wheels of this rider. This rider has a zero turning radius and the rear wheels could fall off the ramps, or the rider could tip over injuring the operator or bystanders.



Starting the Engine

1. While sitting in the operator's seat, make sure the PTO switch is disengaged, the parking brake is engaged, and the ground speed levers are locked in the START/PARK position.
2. Set the engine speed control to the FAST position.
3. Set the choke control to the CHOKE position.
NOTE: A warm engine may not require choking.
4. Insert the key into the ignition switch and turn it to START.
5. After the engine starts, turn off the choke, and warm up the engine by running it for at least a minute before engaging the PTO switch or driving the rider.
6. **After warming the engine, ALWAYS operate the rider at FULL ENGINE SPEED when mowing.**

In the event of an emergency the engine can be stopped by simply turning the ignition switch to STOP. Use this method only in emergency situations. For normal engine shut down follow the procedure given in *Stopping the Rider and Engine*.

Stopping the Rider and Engine

1. Return the ground speed levers to the middle (or *neutral 'N'*) position to stop rider movement. Pivot the levers outward to lock them in the START/PARK position.
2. Disengage the PTO by pushing down on the PTO switch.
3. Engage the parking brake by moving the parking brake lever forward and to the right.
4. Move the engine speed control to the SLOW position and turn the ignition key to OFF. Remove the key.

Mowing

1. Make sure the PTO switch is disengaged, the parking brake is engaged, the ground speed levers are locked in their START/PARK positions, and the operator is in the seat.
2. Start the engine (see *Starting the Engine*).
3. Set the mower cutting height (see *Cutting Height Adjustment*).
4. Set the engine speed control to FAST.
5. Disengage the parking brake.
6. Engage the PTO by pulling up on the switch.
7. Pivot the ground speed levers in from the START/PARK position to the neutral 'N' position.

8. Begin mowing. See *Operator Safety* for tips on safe mowing practices.
9. When finished, shut off the PTO.
10. Stop the engine (see *Stopping the Rider and Engine*).

Pushing the Rider by Hand

1. Disengage the PTO, engage the parking brake, lock the ground speed levers into their START/PARK positions, turn the ignition OFF, remove the key, and wait for all moving parts to stop.
2. To disengage the transmissions, pull the transmission release levers (**A**, Figure 2), located on either side of the engine, up into the PUSH position.
3. Disengage the parking brake.
The rider can now be pushed by hand.
4. After moving the rider, re-engage the transmissions by pushing the transmission release levers back down to the DRIVE position.



DO NOT TOW RIDER

Towing the unit will cause transmission damage. Do not use another vehicle to push or pull this unit.

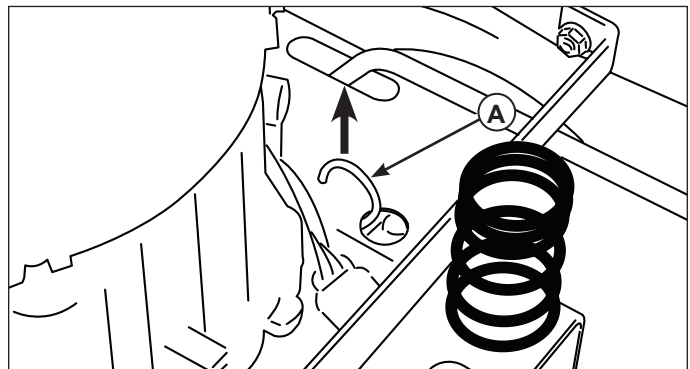

Figure 2. Transmission Release Levers (On Each Side)

! WARNING

DO NOT disengage the transmissions and coast down slopes. **DO NOT** use Transmission Release to disengage the transmissions unless machine motion can be controlled and engine is off.

Zero Turn Driving Practice

The ground speed levers of the zero turn rider are responsive, and learning to gain a smooth and efficient control of the rider's forward, reverse, and turning movements will take some practice.

Spending some time going through the maneuvers shown and becoming familiar with how the unit accelerates, travels, and steers — before you begin mowing — is absolutely essential to getting the most out of the zero turn rider.

Locate a smooth, flat area of your lawn — one with plenty of room to maneuver. (Clear the area of objects, people and animals before you begin.) Operate the unit at mid-engine speed during this practice session (ALWAYS operate at full engine speed when mowing), and turn slowly to prevent tire slippage and damage to your lawn.

We suggest you begin with the Smooth Travel procedure to the right, and then advance through the forward, reverse, and turning maneuvers.

Smooth Travel

The ground speed levers of the zero turn rider are responsive.

The BEST method of handling the ground speed levers is in three steps — as shown in Figure 3.

FIRST place your hands onto the levers as shown.

SECOND, to go forward gradually push the levers forward with your palms.

THIRD, to speed up, move the levers farther forward. To slow down smoothly, slowly move the levers toward neutral.

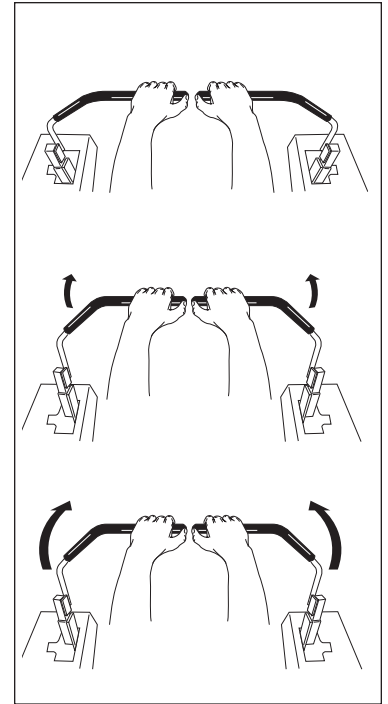

Figure 3. Move Ground Speed Levers Gradually

Basic Driving

Forward Travel Practice

Gradually move both ground speed levers — evenly FORWARD from neutral. Slow down and repeat.

Straight forward travel takes practice. If necessary, top speed can be balance-adjusted — see **Speed Balancing Adjustment** section.

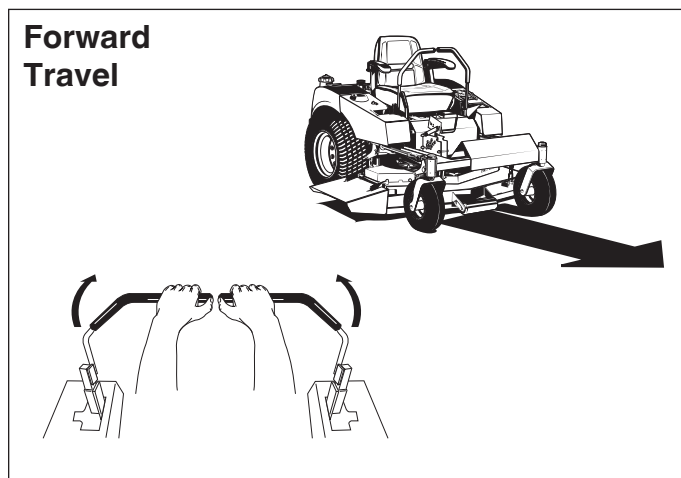

Figure 4. Forward Travel

Reverse Travel Practice

LOOK DOWN & BEHIND, then gradually move both ground speed levers evenly BACK from neutral. Slow down and repeat.

Practice backing up for several minutes before attempting to do so near objects. The rider turns as sharply in reverse as when going forward, and backing up straight takes practice.

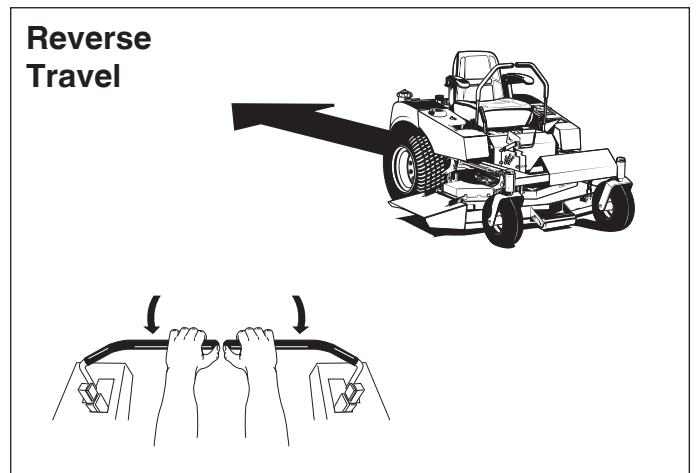

Figure 5. Reverse Travel

Practice Turning Around a Corner

While traveling forward allow one lever to gradually return back toward neutral. Repeat several times.

To prevent pivoting directly on the tire tread, it is best to keep both wheels going at least slightly forward.

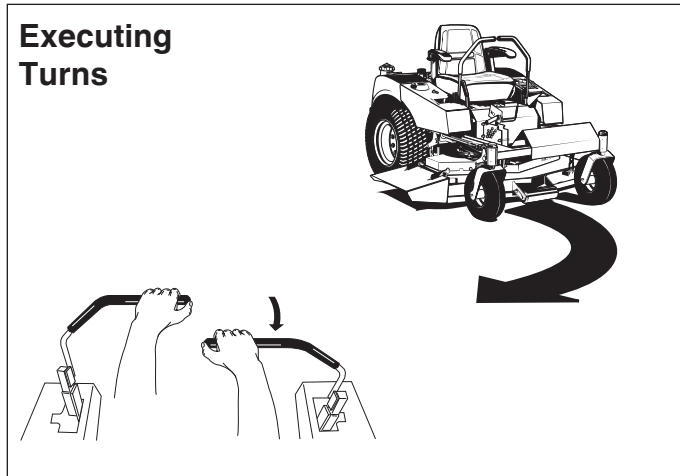

Figure 6. Turning Around a Corner

Practice Turning In Place

To turn in place, “zero turn,” gradually move one ground speed lever forward from neutral and one lever back from neutral simultaneously. Repeat several times.

Changing the amount each lever is pulled — forward or back, changes the “pivot point” you turn on.

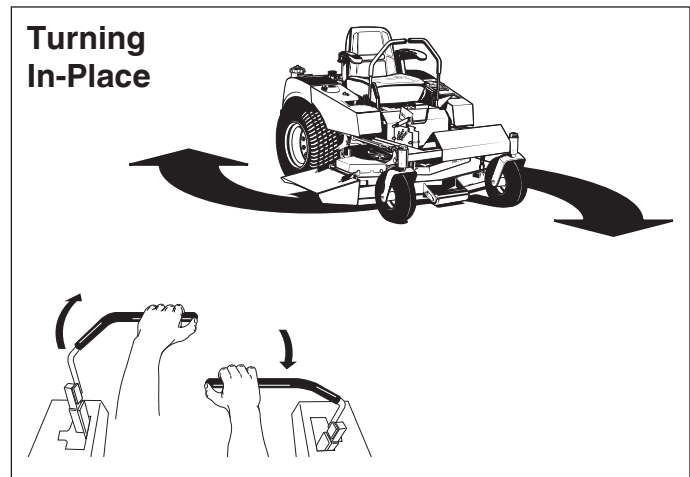

Figure 7. Turning in Place

Advanced Driving

Executing an End-Of-Row Zero Turn

Your zero turn rider's unique ability to turn in place allows you to turn around at the end of a cutting row rather than having to stop and Y-turn before starting a new row.

For example, to execute a right end-of row zero turn:

1. Slow down at the end of the row.
2. Move the LEFT ground speed lever forward slightly while moving the RIGHT ground speed lever back to center and then slightly back from center.
3. Begin mowing forward again.

This technique turns the rider RIGHT and slightly overlaps the row just cut — eliminating the need to back up and re-cut missed grass.

As you become more familiar and experienced with operating the zero turn rider, you will learn more maneuvers that will make your mowing time easier and more enjoyable.

Remember, the more you practice, the better your control of the rider will be!

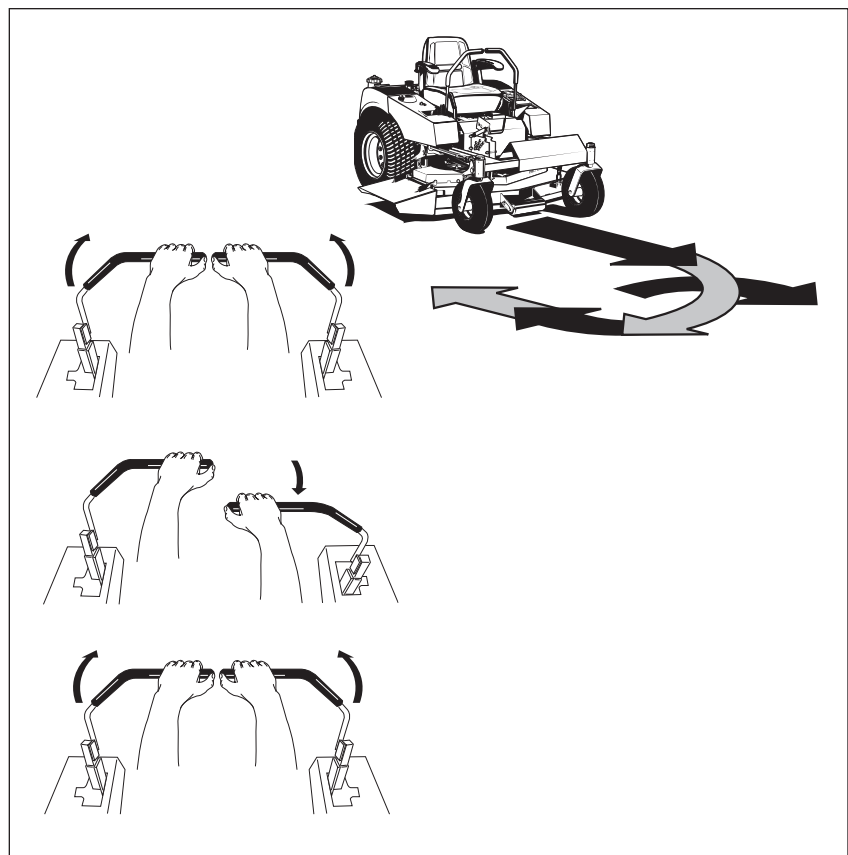

Figure 8. Executing an End-Of-Row Turn

Attaching a Trailer

The maximum weight of a towed trailer should be less than 200 lbs (91 kg). Secure the trailer with an appropriately sized clevis pin (A, Figure 9) and clip (B).

Excessive towed loads can cause loss of traction and loss of control on slopes. Reduce towed weight when operating on slopes. The surface being driven on greatly impacts traction and stability. Wet or slippery surfaces can greatly reduce traction and the ability to stop or turn. Carefully evaluate the surface conditions before operating the unit and trailer, and never operate on slopes greater than 10°. See **Protection Against Tipovers and Towing** in the **Operator Safety** section of this manual.

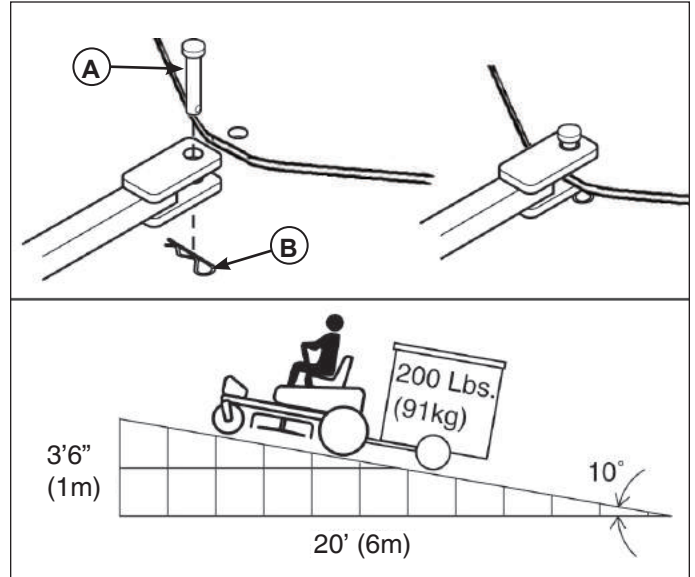

Figure 9. Trailer Weight Recommendations

Maintenance

Maintenance Chart

RIDER AND MOWER
Every 8 Hours or Daily
Check safety interlock system
Clean debris off rider and mower deck
Clean debris from engine compartment
Every 25 Hours or Annually *
Check tire pressure
Check mower blade stopping time
Check rider and mower for loose hardware
Every 50 Hours or Annually *
Check rider brakes
See Dealer Annually to
Lubricate rider and mower
Clean battery and cables
Check mower blades **

* Whichever comes first

** Check blades more often in regions with sandy soils or high dust conditions.

ENGINE
First 5 Hours
Change engine oil
Every 8 Hours or Daily
Check engine oil level
Every 25 Hours or Annually *
Clean engine air filter and pre-cleaner **
Every 50 Hours or Annually *
Change engine oil
Replace oil filter
Annually
Replace air filter
Replace pre-cleaner
See Dealer Annually to
Inspect muffler and spark arrester
Replace spark plug
Replace fuel filter
Clean engine air cooling system

* Whichever comes first

** Clean more often in dusty conditions or when airborne debris is present.

Check Tire Pressures

Tire pressure should be checked periodically, and maintained at the levels shown in the chart. Note that these pressures may differ slightly from the “Max Inflation” stamped on the side-wall of the tires. The pressures shown provide proper traction, improve cut quality, and extend tire life.

Checking / Adding Fuel

To add fuel:

1. Remove the fuel cap.
2. Fill the tank to the bottom of the filler neck.

IMPORTANT: Do not overfill the fuel tank. Stop filling the tank when fuel collects in the filler neck.

NOTE: Refer to your engine manual for specific fuel recommendations.

3. Install and hand tighten the fuel cap.

Fuel Filter

The fuel filter is located in the fuel line between fuel tank and fuel pump. If the filter is dirty or clogged, replace as follows:

1. Disconnect the negative battery cable.
2. Place a container below the filter to catch spilled fuel.
3. Using pliers, open and slide hose clamps from fuel filter (A, Figure 11).
4. Remove hoses from filter.
5. Install new filter in proper flow direction in fuel line.
6. Secure with hose clamps.
7. Reconnect the negative battery cable when finished.

Engine Maintenance

Refer to engine manual for all engine maintenance procedures and recommendations.

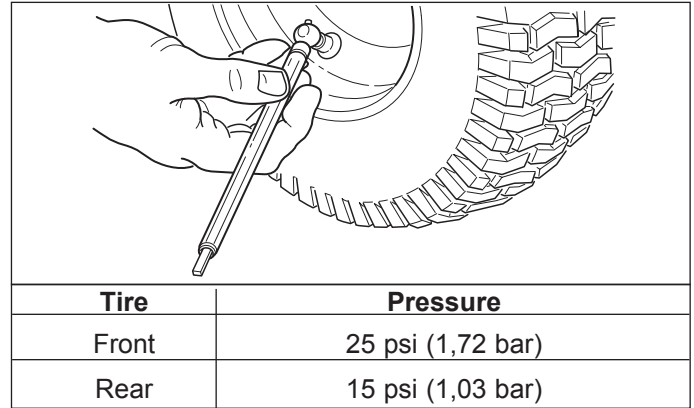

Figure 10. Checking Tire Pressure

WARNING

Gasoline is highly flammable and must be handled with care. Never fill the tank when the engine is still hot from recent operation. Do not allow open flame, smoking or matches in the area. Avoid over-filling and wipe up any spills. Do not remove fuel filter when engine is hot, as spilled gasoline may ignite. DO NOT spread hose clamps further than necessary. Ensure clamps grip hoses firmly over filter after installation.



Do not use gasoline containing METHANOL, gasohol containing more than 10% ethanol, gasoline additives, premium gasoline, or white gas because engine/fuel system damage could result.

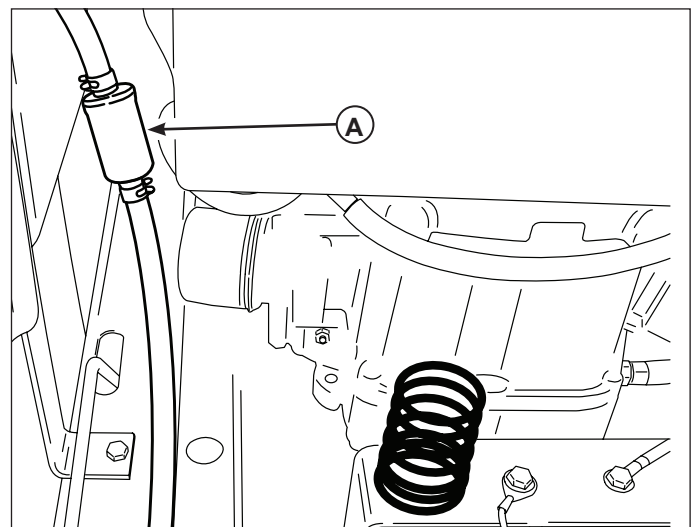

Figure 11. Fuel Filter Replacement
(View looking back from battery compartment)

Storage

Before you store your unit for the off-season, read the **Maintenance and Storage** instructions in the **Operator Safety** section, then perform the following steps:

- Disengage the PTO, move the ground speed levers into the START/PARK positions, set the parking brake, & remove the key.
- Perform engine maintenance and storage measures listed in the engine owner's manual. This includes draining the fuel system, or adding stabilizer to the fuel (do not store a fueled unit in an enclosed structure - see warning).
- Battery life will be increased if it is removed, put in a cool, dry place and fully charged about once a month. If the battery is left in the unit, disconnect the negative cable.

Before starting the unit after it has been stored:

- Check all fluid levels. Check all maintenance items.
- Perform all recommended checks and procedures found in the engine owner's manual.
- Allow the engine to warm up for several minutes before use.

WARNING

Never store the unit (with fuel) in an enclosed, poorly ventilated structure. Fuel vapors can travel to an ignition source (such as a furnace, water heater, etc.) and cause an explosion.

Fuel vapor is also toxic to humans and animals.

Seat and Ground Speed Lever Adjustments

The seat and ground speed levers should be adjusted so that operator's elbows are supported by the arm rests when his/her hands are on the controls, and the ground speed levers can be moved through their full range of motion without contacting the operator's legs.

Seat Position Adjustment

Remove the knobs (A, Figure 12), and loosen the support bolts (B). Slide the seat to the desired position, then reinstall the knobs and retighten the bolts.

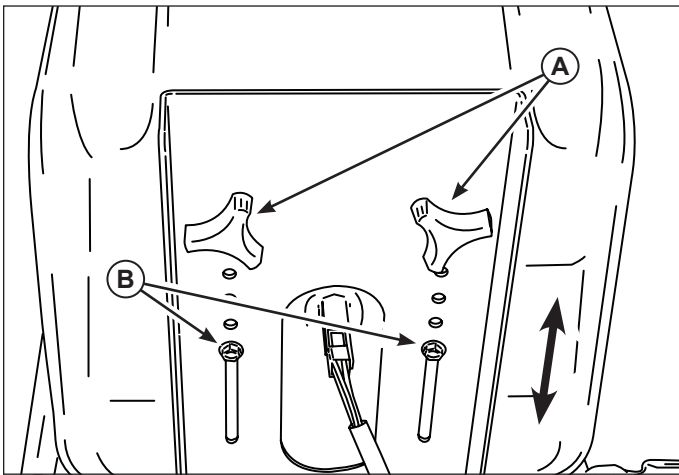

Figure 12. Seat Adjustment

Ground Speed Lever Adjustment

Remove the ground speed lever mounting hardware and bracket (see Figure 13). Move the levers to the desired height using the adjustment holes. The bolts need to be spaced so there is a hole open in between. Reinstall the bracket and mounting hardware to the levers.

Speed Balancing Adjustment

If the rider drifts to the right or left when the ground speed levers are in the maximum forward position, the top speed of each of these levers can be balanced. Only adjust the speed of the wheel that is traveling faster.

Loosen the bolt securing the forward adjust plate (see Figure 14). Slide the plate up approximately 1/8". Retighten the bolt and recheck speed balance. Repeat steps until adjustment is complete.

⚠ WARNING

DO NOT adjust the rider for a faster overall speed forward or reverse than it was designed.

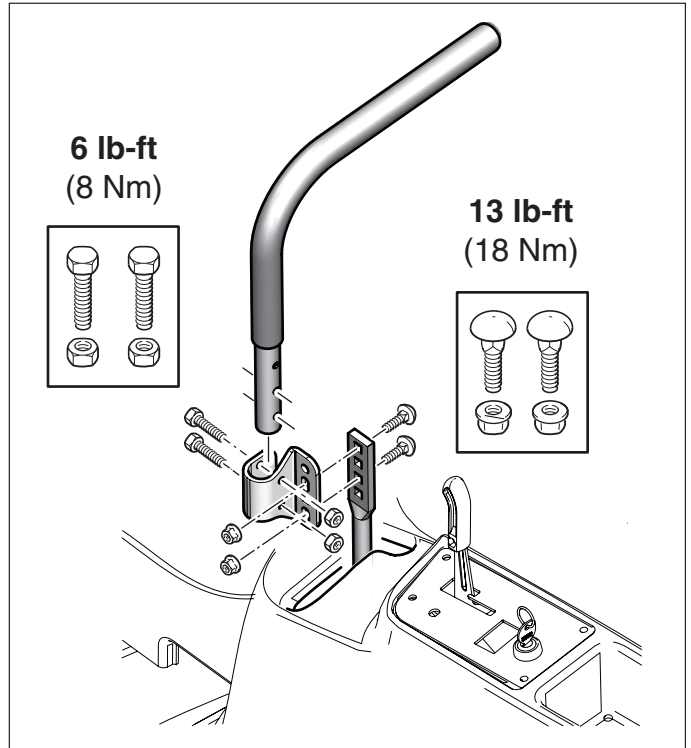

Figure 13. Ground Speed Lever Adjustment

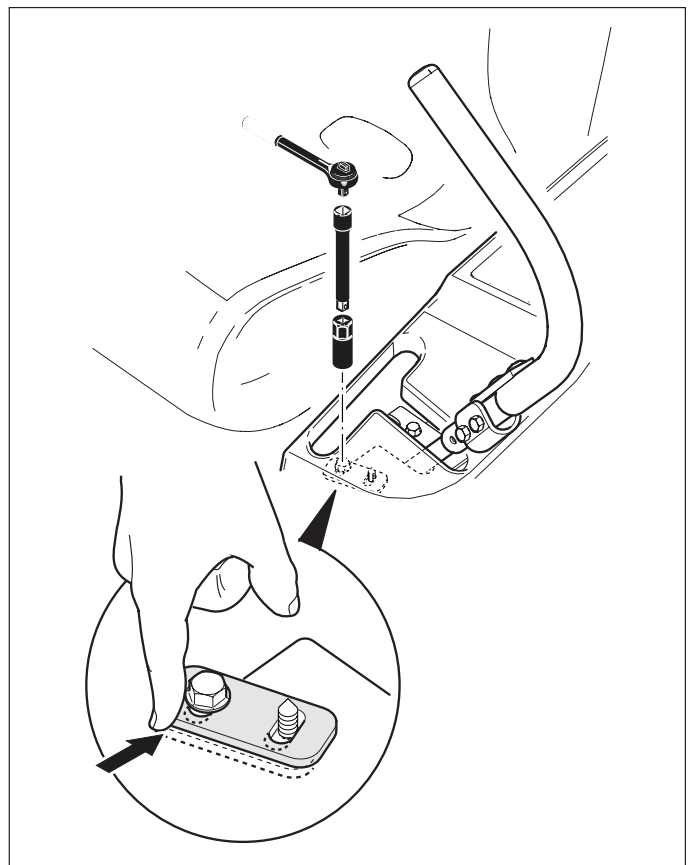

Figure 14. Speed Balancing Adjustment

Cutting Height Adjustment

The cutting height adjustment switch controls the mower cutting height. The cutting height is adjustable between 1.75" (4,4 cm) and 4.0" (10,0 cm).

To adjust cutting height:

Press the adjustment switch (A, Figure 15) forward to lower the mower deck, backward to raise the mower deck.

The slot in the cutting height indicator (B) indicates the cutting height of the mower deck.

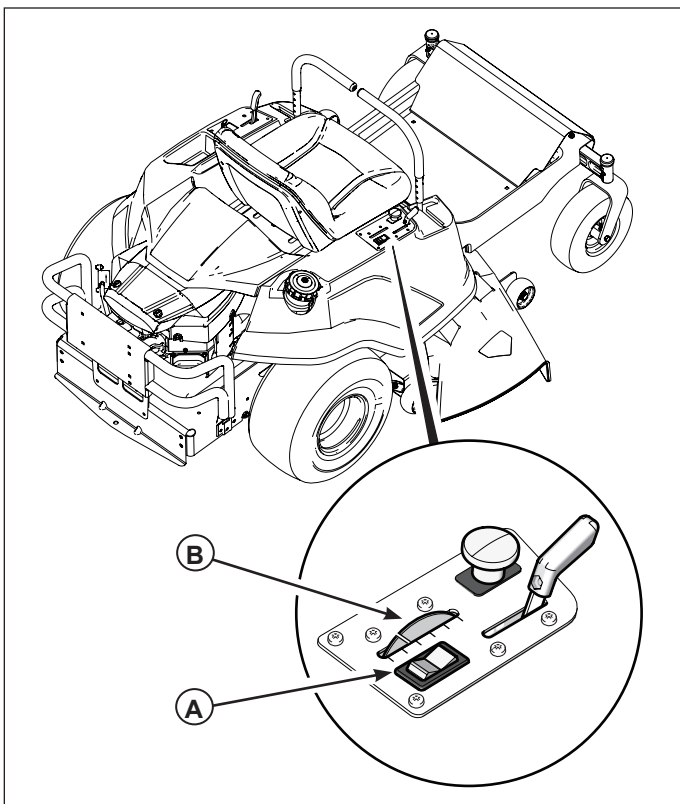

Figure 15. Cutting Height Adjustment

Mower Removal and Installation

NOTE: Perform mower removal and installation on a hard, level surface such as a concrete floor.

WARNING

After lowering the mower cutting height, engage parking brake, turn off the mower blades, turn the ignition switch to STOP, and remove key before attempting to install or remove the mower.

Removal

1. Turn the mower blades OFF, put the ground speed control levers in START/PARK position, engage the parking brake, turn the ignition OFF, and wait for all moving parts to stop.
2. Pivot the front wheels forward.
3. Use the mower belt lever (A, Figure 16) to release belt tension. Remove the mower belt (B) from engine pulley (C).

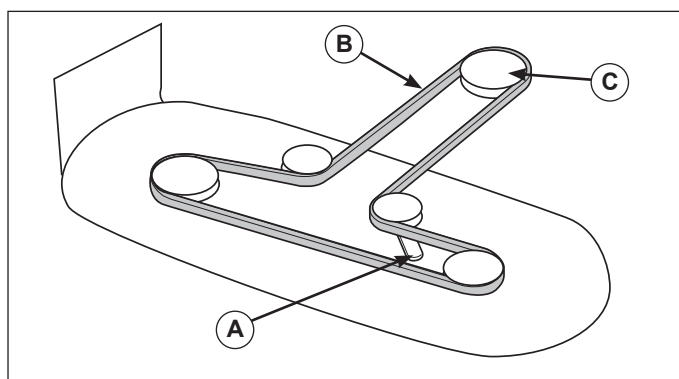

Figure 16. Remove and Install Mower Belt

4. Turn the ignition switch from OFF to RUN without starting the engine.
5. Use the mower cutting height switch to raise the mower deck.
6. Place 4x4 wood blocks under the front and rear lip of the mower deck to securely support it.
7. Use the mower cutting height switch to fully lower the mower so that it is resting on the 4x4 wood blocks.
8. Turn the ignition switch to OFF and remove the key.
9. Remove the hair pin clips (A, Figure 17) and washers (B) that secure the rear lift arms (C). Separate the rear lift arms from the mower deck.

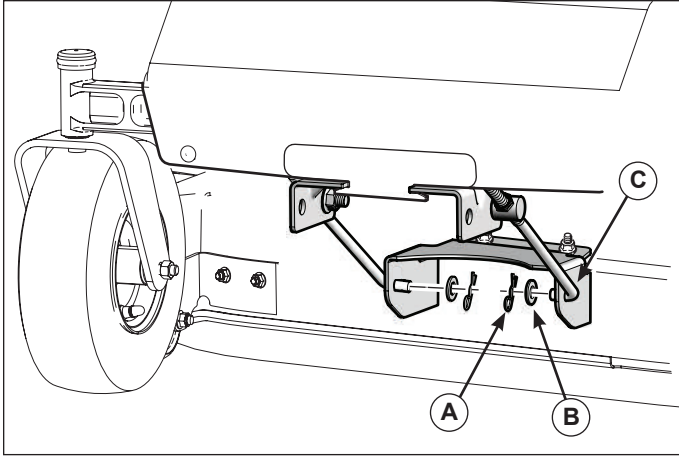

Figure 17. Rear Lift Arms

10. Remove the hair pin clips (A, Figure 18) and washers (B) that secure the front hitch rods (C). Separate the front hitch rods from the mower deck.
11. Slide the mower deck out from under the rider.

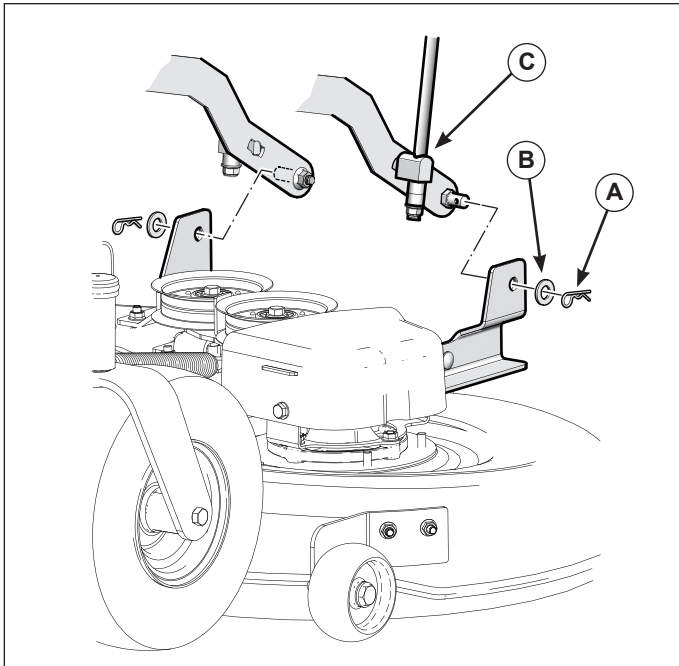

Figure 18. Front Lift Arms

Installation

1. Slide the mower deck under the right side of the rider.
2. Slide the mower deck forward and connect the front hitch rods to the mower deck. Secure with washers (B, Figure 18) and hair pin clips (A).
3. Slide the mower deck backward and connect the rear lift arms to the mower deck. Secure with washers (B, Figure 17) and hair pin clips (A).
4. Insert the key into the ignition switch. Turn the switch from OFF to RUN without starting the engine.
5. Use the cutting height switch to raise the mower until it is no longer resting on the 4x4 wood blocks.
6. Turn the ignition switch OFF and remove the key. Remove the 4x4 blocks.
7. Use the mower belt lever (A, Figure 16) to release belt tension, and install the mower belt (B) as shown.

!WARNING

To avoid serious injury, perform adjustments only with engine stopped, key removed and rider on level ground.

Check Mower Blade Stopping Time

Mower blades and mower drive belt should come to a complete stop within 5 seconds after electric PTO switch is turned off.

1. With parking brake engaged, PTO disengaged and an operator in the seat, start the engine.
2. Have an assistant observe the mower drive belt through the opening between the frame and top of mower deck. Engage the PTO and wait several seconds. Disengage the PTO and check the amount of time it takes for the mower drive belt to stop.
3. If the mower drive belt does not stop within 5 seconds, see an authorized dealer.

Cleaning the Battery and Cables

1. Disconnect the cables from the battery, negative cable first (C, Figure 19).
2. Clean the battery terminals and cable ends with a wire brush until shiny.
3. Reinstall the battery and reattach the battery cables, positive cable first (A).
4. Coat the cable ends and battery terminals with petroleum jelly or non-conducting grease.
5. Be sure to replace the terminal cover (B) over the positive battery terminal.

Battery Charging

A dead battery or one too weak to start the engine may be the result of a problem in the charging system or other electrical component. If there is any doubt about the cause of the problem, see your dealer. If you need to replace the battery, see **Cleaning the Battery and Cables** section.

To charge the battery, follow the instructions provided by the battery charger manufacturer as well as all warnings included in the safety section of this book.

1. Remove the battery from the rider and place on a level, non-concrete surface in a well-ventilated area.
2. Connect a 12-volt battery charger to the battery terminals; RED to positive (+) and BLACK to negative (-) terminal.
3. Charge the battery at 6-10 amps for 1 hour. Do not charge at a rate higher than 10 amps.

! WARNING

DO NOT use "BOOST" chargers on the battery.
DO NOT attempt to charge battery while installed on the unit.

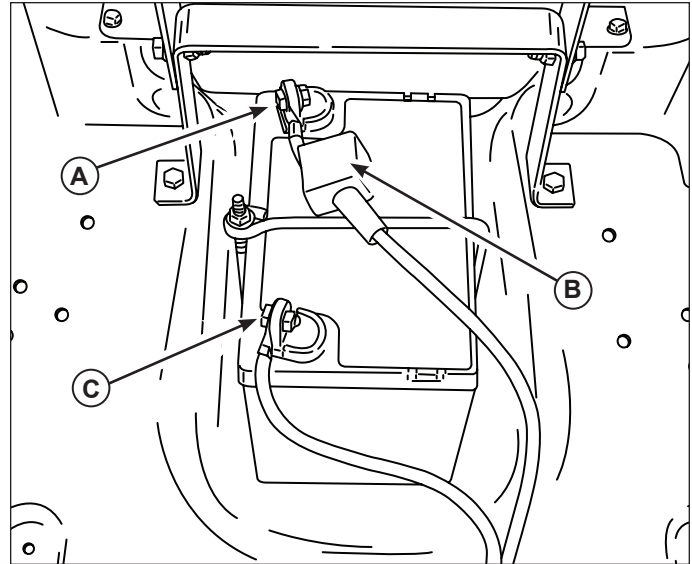

Figure 19. Battery Compartment

! WARNING

Be careful when handling the battery. Keep flames and sparks away from the battery. When removing or installing battery cables, disconnect the negative cable FIRST and reconnect it LAST. If not done in this order, the positive terminal can be shorted to the frame by a tool.

! WARNING

Keep open flames and sparks away from the battery; the gasses coming from it are highly explosive. Ventilate the battery well during charging.

Troubleshooting the Rider

PROBLEM	LOOK FOR	REMEDY
Engine will not turnover or start.	Ground speed levers not in START/PARK positions.	Lock ground speed levers in START/ PARK positions.
	PTO (electric clutch) switch in ON position.	Place in OFF position.
	Out of fuel.	If engine is hot, allow it to cool, then refill the fuel tank.
	Parking brake disengaged.	Engage parking brake.
	Fuel valve closed (if equipped).	Open fuel valve.
	Engine flooded.	Open the choke.
	Gas is old or stale.	Drain fuel and replace with fresh fuel.
	Battery terminals require cleaning.	Clean the battery terminals.
	Battery discharged or dead.	Recharge or replace.
	Wiring loose or broken.	See authorized service dealer.
	Solenoid or starter motor faulty.	See authorized service dealer.
	Safety interlock switch not working.	See authorized service dealer.
	Spark plug(s) faulty, fouled or incorrectly gapped.	Clean and gap or replace. (See engine manual.)
	Water in fuel.	Drain fuel and refill with fresh fuel.
	Circuit breaker blown.	See authorized service dealer.
Engine starts hard or runs poorly.	Fuel mixture too rich.	Clean air filter. Check the choke.
	Spark plug faulty, fouled, or incorrectly gapped.	Clean and gap or replace. (See engine manual.)
	Fuel filter dirty.	Replace fuel filter.
Engine knocks.	Low oil level.	Check/add oil as required.
	Using wrong grade oil.	See engine manual.
Excessive oil consumption.	Engine running too hot.	Check engine fins, blower screen, and air cleaner.
	Using wrong grade oil.	See engine manual.
	Too much oil in crankcase.	Drain excess oil.
Engine exhaust is black.	Dirty air filter.	Replace air filter. (See engine manual.)
	Engine choke control is in closed position.	Open choke control.
Engine runs, but rider will not drive.	Transmission(s) disengaged.	Push transmission release lever(s) into DRIVE position.
	Belt is broken.	See authorized service dealer.
	Drive belt slips.	See authorized service dealer.
	Brake is not fully released.	See authorized service dealer.
	Internal transmission problem.	See authorized service dealer.

PROBLEM	LOOK FOR	REMEDY
Rider drive belt slips.	Pulleys or belt greasy or oily.	Clean as required.
	Belt stretched or worn.	See authorized service dealer.
Brake will not hold.	Brake components worn or damaged.	See authorized service dealer.
	Internal transmission problem.	See authorized service dealer.
Rider steers or handles poorly.	Steering linkage is loose.	Check and tighten any loose connections.
	Improper tire inflation.	See Maintenance section.

Troubleshooting the Mower

PROBLEM	LOOK FOR	REMEDY
Mower will not raise.	Mower deck not properly installed.	See Maintenance section.
	Deck lift components damaged.	See authorized service dealer.
Mower cut is uneven.	Mower not leveled properly.	See authorized service dealer.
	Rider tires not inflated equally or properly.	See Maintenance section.
Mower cut is rough looking.	Engine speed too slow.	See engine speed control to FAST.
	Ground speed too fast.	Decrease ground speed.
	Blades are dull.	See authorized service dealer.
	Mower drive belt slipping because it is oily or worn.	See authorized service dealer.
	Blades not properly fastened to spindles.	See Servicing the Mower Blades.
Engine stalls easily with mower engaged.	Engine speed too slow.	Set engine speed control to FAST.
	Ground speed too fast.	Decrease ground speed.
	Cutting height set too low.	Cut tall grass at maximum cutting height during first pass.
	Discharge chute jamming with cut grass.	Cut grass with discharge pointing toward previously cut area.
Excessive mower vibration.	Blade mounting hardware is loose.	Tighten to 50-60 ft-lbs (68-81 Nm).
	Mower blades, spindles, or pulleys are bent.	See authorized service dealer.
	Mower blades are out of balance.	See authorized service dealer.
	Blade installed incorrectly.	See authorized service dealer.
Excessive belt wear or breakage.	Bent or rough pulleys.	See authorized service dealer.
	Using incorrect belt.	See authorized service dealer.
Mower drive belt slips or fails to drive.	Idler pulley spring broken or not properly attached.	See authorized service dealer.
	Mower drive belt broken.	See authorized service dealer.

Specifications

Engine:

18 HP * Kawasaki

Make Kawasaki

Model FR600

Gross HP * 18 @ 3600 rpm

Displacement 36.8 cu in. (603 cc)

Electrical System Battery 12 Volt, 230 CCA
Alternator 15 amp

Oil Capacity 58 oz (1,7 L) w/Filter

Chassis:

Fuel Tank Capacity: 2.4 Gallons (9,1 L)

Rear Wheels Tire Size: 18 x 8.50-8

Inflation Pressure: 15 psi (1,03 bar)

Front Wheels Tire Size: 11 x 4.00-5

Inflation Pressure: 25 psi (1,72 bar)

Transmissions:

Make Hydro Gear

Type EZT

Hydraulic Fluid Sealed Unit

Speeds Forward: 0-6 MPH (0-9.66 km/h)

@ Specified rpm Reverse: 0-3 MPH (0-4.83 km/h)

Dimensions:

Overall Length 75" (191 cm)

Overall Width 52" (132 cm)

Height 39" (99 cm)

Parts and Accessories

See an authorized dealer.

* Power Ratings:

All power levels are stated gross horsepower per SAE J2723 as rated by Kawasaki and tested per the SAE J1995 test standard. The gross power curves and more information can be viewed at www.kawasaki-criticalpower.com.

Warranty

BRIGGS & STRATTON PRODUCTS WARRANTY POLICY

April 2012

LIMITED WARRANTY

Briggs & Stratton warrants that, during the warranty period specified below, it will repair or replace, free of charge, any part that is defective in material or workmanship or both. Transportation charges on product submitted for repair or replacement under this warranty must be borne by purchaser. This warranty is effective for and is subject to the time periods and conditions stated below. For warranty service, find the nearest Authorized Service Dealer in our dealer locator map at Snapper.com. The purchaser must contact the Authorized Service Dealer, and then make the product available to the Authorized Service Dealer for inspection and testing.

There is no other express warranty. Implied warranties, including those of merchantability and fitness for a particular purpose, are limited to one year from purchase, or to the extent permitted by law. All other implied warranties are excluded. Liability for incidental or consequential damages are excluded to the extent exclusion is permitted by law. Some states or countries do not allow limitations on how long an implied warranty lasts, and some states or countries do not allow the exclusion or limitation of incidental or consequential damages, so the above limitation and exclusion may not apply to you. This warranty gives you specific legal rights and you may also have other rights which vary from state to state or country to country.**

WARRANTY PERIOD

Item	Consumer Use	Commercial Use
Equipment	3 years	90 days
Engine*	3 years	90 days
Battery (if equipped)	1 year	1 year

* Applies to Briggs & Stratton engines only. Warranty coverage of non-Briggs & Stratton engines is provided by that engine manufacturer. Emissions-related components are covered by the Emissions Warranty Statement.

** In Australia - Our goods come with guarantees that cannot be excluded under the Australian Consumer Law. You are entitled to a replacement or refund for a major failure and for compensation for any other reasonably foreseeable loss or damage. You are also entitled to have the goods repaired or replaced if the goods fail to be of acceptable quality and the failure does not amount to a major failure. For warranty service, find the nearest Authorized Service Dealer in our dealer locator map at BRIGGSandSTRATTON.COM, or by calling 1300 274 447, or by emailing or writing to salesenquires@briggsandstratton.com.au, Briggs & Stratton Australia Pty Ltd, 1 Moorebank Avenue, NSW, Australia, 2170.

The warranty period begins on the date of purchase by the first retail consumer or commercial end user, and continues for the period of time stated in the table above. "Consumer use" means personal residential household use by a retail consumer. "Commercial use" means all other uses, including use for commercial, income producing or rental purposes. Once a product has experienced commercial use, it shall thereafter be considered as a commercial use product for purposes of this warranty.

No warranty registration is necessary to obtain warranty on Briggs & Stratton products. Save your proof of purchase receipt. If you do not provide proof of the initial purchase date at the time warranty service is requested, the manufacturing date of the product will be used to determine the warranty period.

ABOUT YOUR WARRANTY

We welcome warranty repair and apologize to you for being inconvenienced. Warranty service is available only through Snapper Authorized Service Dealers. Most warranty repairs are handled routinely, but sometimes requests for warranty service may not be appropriate. This warranty only covers defects in materials or workmanship. It does not cover damage caused by improper use or abuse, improper maintenance or repair, normal wear and tear, or stale or unapproved fuel.

Improper Use and Abuse - The proper, intended use of this product is described in the Operator's Manual. Using the product in a way not described in the Operator's Manual or using the product after it has been damaged will void your warranty. Warranty is not allowed if the serial number on the product has been removed or the product has been altered or modified in any way, or if the product has evidence of abuse such as impact damage, or water/chemical corrosion damage.

Improper Maintenance or Repair - This product must be maintained according to the procedures and schedules provided in the Operator's Manual, and serviced or repaired using genuine Briggs & Stratton parts or equivalent. Damage caused by lack of maintenance or use of non-original parts is not covered by warranty.

Normal Wear - Like all mechanical devices, your unit is subject to wear even when properly maintained. This warranty does not cover repairs when normal use has exhausted the life of a part or the equipment. Maintenance and wear items such as filters, belts, cutting blades, and brake pads (except engine brake pads) are not covered by warranty due to wear characteristics alone, unless the cause is due to defects in material or workmanship.

Stale Fuel - In order to function correctly, this product requires fresh fuel that conforms to the criteria specified in the Operator's Manual. Damage caused by stale fuel (carburetor leaks, clogged fuel tubes, sticking valves, etc) is not covered by warranty.

Other Exclusions - This warranty excludes damage due to accident, abuse, modifications, alterations, improper servicing, freezing or chemical deterioration. Attachments or accessories that were not originally packaged with the product are also excluded. There is no warranty coverage on equipment used for primary power in place of utility power or on equipment used in life support applications. This warranty also excludes failures due to acts of God and other force majeure events beyond the manufacturer's control.

